

Service Planning System for Large-scale High Speed Railway Network

Zhenhuan He, Lei Nie, Huiling Fu

School of Traffic & Transportation, Beijing Jiaotong University, Beijing, China

Email: zhhe@bjtu.edu.cn, {lnie, hl fu}@bjtu.edu.cn

Abstract—Due to its important role in high speed railway operation, service planning is always focused on by the researchers. With the development of computer technology, some systems have been researched to help operators and researchers to get satisfied service plan. The paper researches such a system for large-scale high speed railway network. It analyzes the main process of service planning firstly and presents the mainframe of the system based on the construction principle of multi-stages and multi-levels. The related key technologies are researched consequently. For highly applicable system control, a highly configurable system control method is put forward to control the runtime environment and optimizing process flexibly. Then a system construction technique based on multi-level loosely coupled bus and hierarchical control is proposed. The multi-granularity data management with strong constraints is also researched for the large-scale data management with complicated relationship. Finally, the demonstration of train service planning in multi-granularity is researched in order to provide strong and intelligent support for users' decision from different views. The system has been developed by C#. Its feasibility and effectiveness have been proven by a sample of service planning for a network relative to Jinghu high speed railway.

Index Terms—train service planning, high speed railway, information technology, railway traffic and transportation

I. INTRODUCTION

Service planning (SP) for passenger trains is always an important problem in railway operation. It's an integrated plan that describes the key factors of the trains including train path, quantity, stop schedule, train types, train components, operation time, etc. It was commonly the main object to make full use of railway capacity, maximize the benefits of the railway enterprise and minimize the cost of passengers. Service planning is the fundamental plan of high-speed railway operation and, furthermore, will make important impact on the following plans. Since then, it's significant to make a scientific and practical service planning for high-speed railway operation.

The researchers in Dutch and Germany paid their

Manuscript received June 7, 2013; revised Sep. 12, 2013; accepted Sep. 14, 2013.

Correspondence should be addressed to Zhenhuan He, E-mail: zhhe@bjtu.edu.cn

attention to this problem several decades ago. With quickly development of computer technology, the models and algorithms for the optimization of service planning in large scale railway network with computers were widely researched in recent decade [1-6]. The similar research in Korea, Japan and Taiwan focused mainly on some separate lines rather than networks since their networks are relative small. The main contents of service planning of European railway companies were to make some adjustment in existing ones since they have generally accumulated plenty of experience and there weren't great change both in their network and the passengers. They paid most attention to the evaluation, feedback and corresponding adjustment for service planning and some simulation tools such as NEMO[7], SIMONE[8], PLATO[9], etc. were hereby developed to make some help. However, service planning was commonly considered as a part of marketing and there were seldom special or separate system for it.

In China, the research on high-speed railway service planning started much later than Europe. Shi Feng[10-11], Fu Huiling[12-14], Deng Lianbo[15], etc. researched on the problem from different views. Some models including bi-level programming model, mixed integer programming model, etc. had been constructed and some pure mathematic or intelligent optimization algorithms had been also created. Furthermore, Hu Hui[16], Za Weixiong[17], Shi Feng[18] researched the service planning system which could give us some good reference. However, since those systems were mainly only for research or some experiments, their applicability for service planning for large scale network needed further research and verification. Generally speaking, it's lack of the systems with strong practicality in China.

Chinese high speed railway network was constructed so quickly that there's no the accumulation of operation experience. Therefore, it's the main work in Chinese high speed railway to make completely new service planning. It's so different with those in foreign railways that there's no existing system for reference. In addition, Chinese high speed railway network has large scale and passed the areas with complicated society and economy conditions. The service planning of the lines passing different areas will be constrained by different passengers, transport resources, line conditions, etc. which caused that diverse operation mode should be applied. The models, algorithms and parameters will differ accordingly. As the

result, the difficulty of service planning system will arise remarkably. Since then, it has important theoretical and practical value to research and develop such a system that could adapt to service planning of Chinese high speed railway network.

II. ANALYSIS OF BASIC PROCESS OF SERVICE PLANNING FOR LARGE SCALE NETWORK BY COMPUTER

Due to the high complexity of service planning in large scale network, the system must have high adaptability,

intelligence and practicality so that it can adapt to diverse operation modes, objectives and the constructing process under various constraints in which different models and algorithms will be applied. Furthermore, adequate user decisions should be permitted in the process to ensure the practicality by the help of experts' experience. In order to develop the integrated optimization system with the characteristics above, a multi-stage layered method is applied and 6 main steps comprise a hierarchical optimization process, shown as Figure 1.

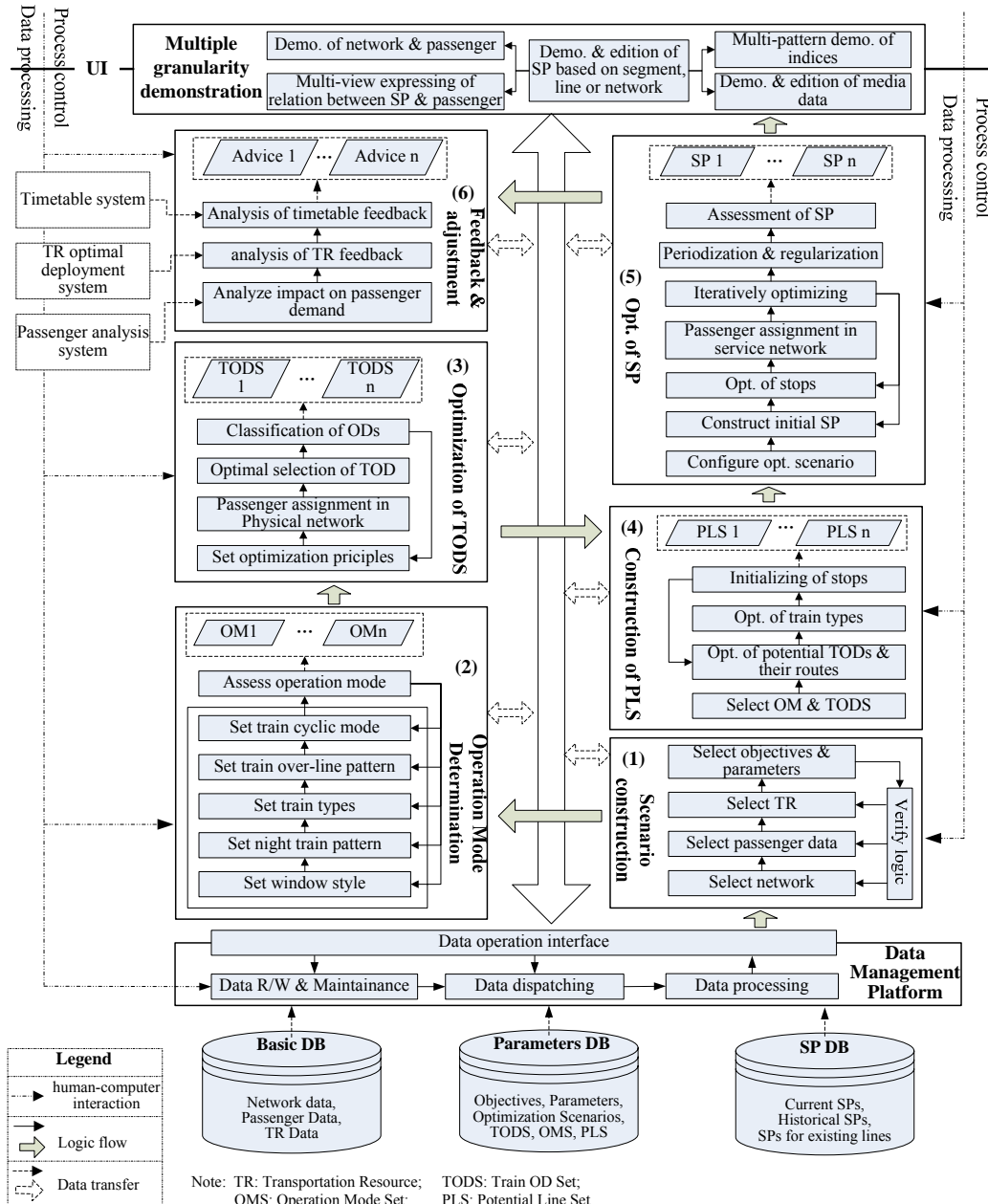

Figure 1. Basic process of computer-aided construction of high-speed SP

The following key technologies must be researched to construct the system:

1) Models and algorithms for service planning that can adapt to the process in Figure 1. Many researchers including authors have studied on the problem so much [18-20] in the past years so that the paper will apply the

results directly and pay more attention to the construction of the system itself.

2) SP construction process and its control with high adaptability. The system must be able to control the SP construction logic flexibly to adapt to various operation modes. Therefore, the data and modules are able to be

configured and combined randomly to build the needed logic process. The highly open system construction technologies should be used in turn to meet the demand above. Thus, highly configurable system control and multi-layer buses and hierarchical control technology based on loose coupling will be used in the system.

3) Data management under powerful logic constraints. Each step in the process of SP construction will produce much data that have strict logical and/or sequential relationship between each other. It's the key work to maintain them and select right data for current procedure according to all kinds of existing logic. So multiple-granularity data management technology under powerful logical constraints will be applied.

4) Multiple-granularity demonstration with strong intelligence-aided decision support functions. Due to its numerous factors and their complex relations, it's so hard to users to assess the SP quickly and exactly. It's necessary to express SPs and their mediate results from different views and granularities and in different forms. Therefore, many key data such as the performance of SPs from different views, the detailed matching data of trains and passengers, etc. should be fully demonstrated. They can help users to assess SPs fully and objectively in order to make accurate decisions. Only in this way can the mathematical optimization and manual decision be cooperated well to make high-quality SPs.

III. HIGHLY CONFIGURABLE PROCESS CONTROL

Highly configurable process control here mainly means that the objectives, parameters and the process can be configured flexibly in the process of optimization. Users can select suitable objects (network, passenger, etc.), objectives, parameters, models, algorithms and process according to their demands and data characteristics and adjust them manually based on the optimizing result of each step in the process[19], shown as Figure 2.

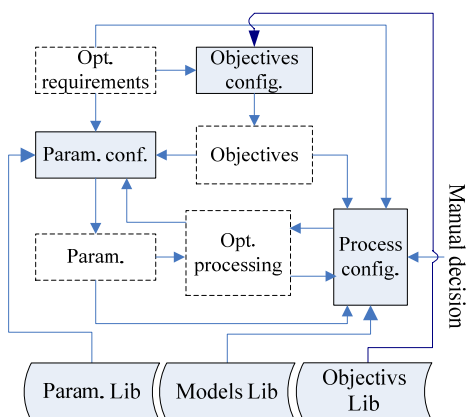

Figure 2. Highly configurable system control

Before SP construction, the control should be emphasized on the creation of working area, shown as figure 1. Suitable objects will be selected to adapt to the SP construction of single line, local network or whole network. The system will search suitable models and

algorithms for each step from system model library and thereby the framework of optimizing process will be established initially.

The optimizing process is composed of several steps and there may be several models suitable to different situations for each step. Therefore, the emphasis of system control is how to configure and adjust the model, algorithm, parameters and process more detailedly and in time. Following key problems have been researched consequently. 1) The system should be able to select successive modules according to current result. For example, if the operation mode selected in step 2 in Figure 1 isn't a periodic type, the module of periodization & regularization in step 5 won't be executed. 2) The system can control iteration among main steps or/and their internal process. 3) Some modules and sub-modules can be substituted with existing data such as OMS, PLS, and so on to fulfill the different requirements. 4) Manual intervention and decision can be done in any key node of each step in order to improve the feasibility of SP.

In addition, the system will select suitable parameters automatically according to the previous ones and optimizing result and, furthermore, permit users to modify them to ensure the quality of final result.

IV. MULTI-LAYER BUSES AND HIERARCHICAL CONTROL TECHNOLOGY BASED ON LOOSE COUPLING

The technology is adopted in order to fulfill the demand of "configurable", too. It can give the modules strong independence and decrease their coupling level between each other so that they can make more freely combination.

The system is divided into several independent subsystems with relatively full functions such as OM management, TOD management, PL management, etc. according to the characteristics and demands of SP optimization. The separated dispatching subsystem, that is the system bus, is also designed to ensure the good control of the system. It had 2 main functions: 1) to configure and manage the optimization process; 2) to manage and dispatch all the data uniformly. The mainframe of the system structure is shown as Figure 3.

Hierarchical structure is also applied within the subsystems so as to organize their functions and data by layers, too. It will take optimization subsystem whose main function is to accomplish the core optimization process as example to describe this construction mode in the following content.

The process in the subsystem can be divided into several independent steps including optimization preparation, initial service planning creation, stops optimization, etc. which construct different layers respectively and some interfaces are defined between each two adjacent layers. There's also a bus (or sub-bus) within the subsystem which functions consists of 2 parts: 1) to manage the whole process including configuration and calling of modules used in different layers and control of iteration of the process; 2) to exchange the data with main bus of the system and collect the suitable data for current subsystem and manage all the data in the

subsystem. So the construction mode of "sub-bus + hierarchical control" came into being in the subsystem,

shown as Figure 4. By this mode, the users can set most

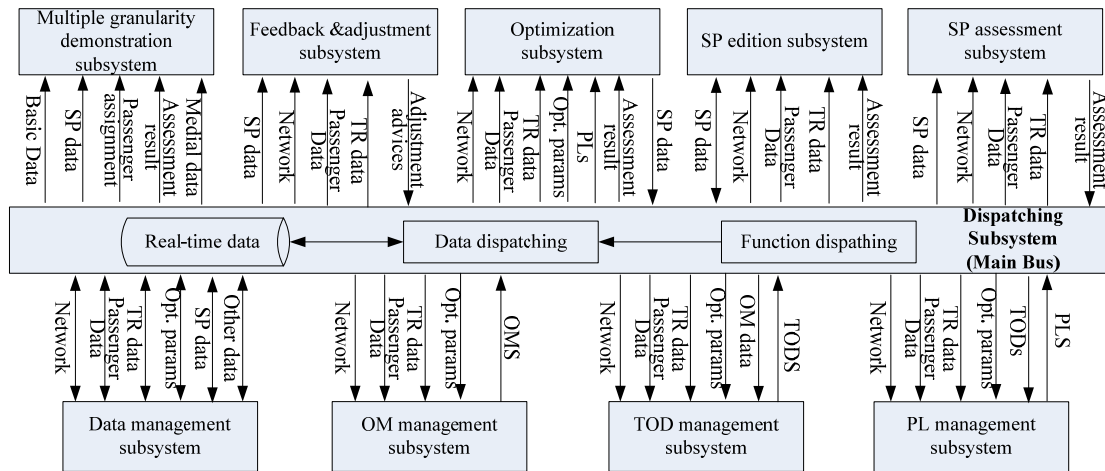

Figure 3. Mainframe of the system

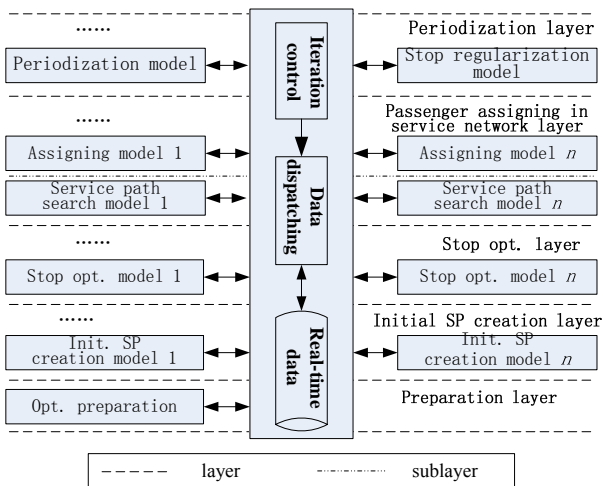

Figure 4. Construction of SP optimization subsystem

suitable models and algorithms for optimization process according to the different objects and demands so that the control of the system is more flexible.

Three or more levels development model, that is, interface –abstract class – realization class, are applied in system developing. Interfaces are used to define the essential functions of current layer or sub-layer. Abstract classes are developed to accomplish the basic or public functions. Realization classes are corresponding to different models and algorithms that can be used in current layer or sub-layer. The real functions of the modules are implemented here. In addition, the realization classes are possibly derived to extend some functions to fulfill more demands.

V. DATA MANAGEMENT WITH STRONG LOGIC CONSTRAINTS

The data in the system are mainly constrained by 3 factors: space, time and logic sequence. The space and time constraints determine what network, passenger data and transportation resource will be extracted from the

complete data by the system to construct basic environment. The logic sequence obtains the logic order and dependence between each 2 data.

There will be many result branches in each step of optimization since different models, objects or parameters can be applied. A large and complicated data tree shown as Figure 5 will be constructed in the system[20]. The data of each node will give strict logic sequence limit to all the data in its descendant nodes.

It's thus the main data management work to extract, reconstruct and process data exactly according to control and logic demand in order to ensure their correctness and convenience in the process of optimization. Therefore, logical relationship maintenance and data organization become the key problems.

In order to solve the first problem, the relations between each data node and its father or child nodes will be recorded and a bi-directional data tree is built. Furthermore, a corresponding logic management module is also been created specially to check and maintain the logical relationship efficiently. When some data, e.g. service planning data, will be loaded and used, all related data can be indexed and loaded at one time to be used in further analysis or optimization.

After that the data management from horizontal and vertical dimensions is been constructed in order to keep good data organization, shown as Figure 5. The horizontal management is mainly categorized by data types. Some logical management classes are developed hereby to manage the data of different types respectively in order to operate the data of same type efficiently. The network manager, passenger data manager, etc. in Figure 5 are all belong to this type. The main task of vertical management is to maintain the logical relationship of the data. The optimal data manager is the main vertical data manger. The data selected in each optimization step will be managed uniformly here to make current data environment[21]. The data created in each step will be sent to the data manager of its own type firstly. Then the

suitable data in accordance with user decision or optimization requests will be selected and put into current

data environment to fulfill the further optimization and

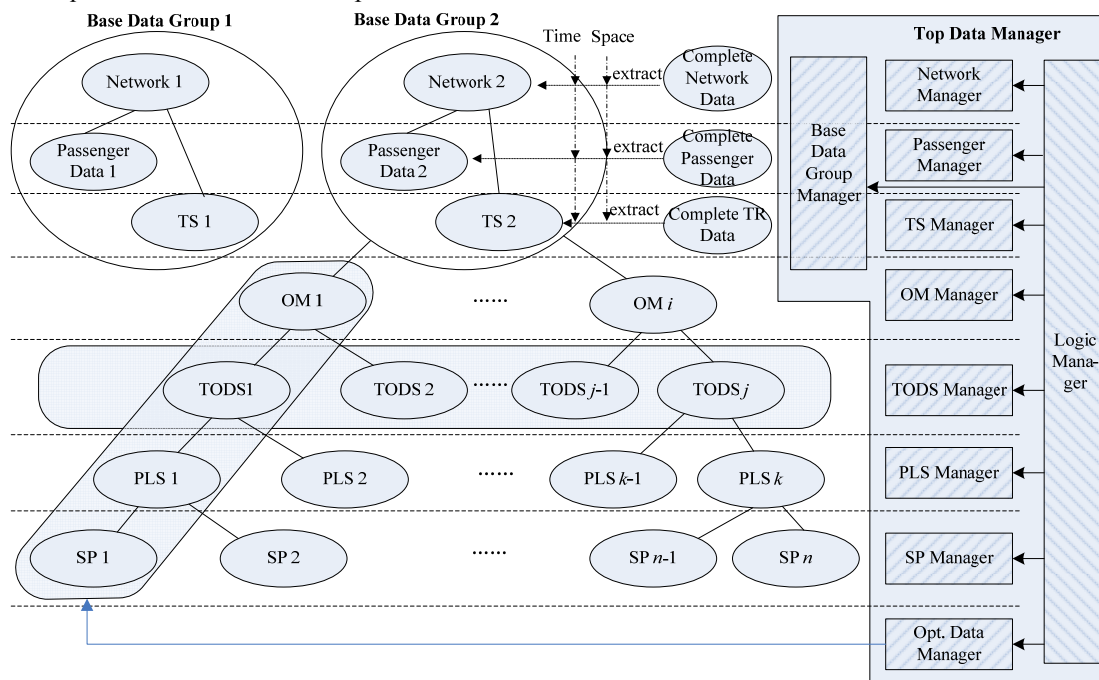

Figure 5. Data logical structure and management

analysis. The logic manager shown in Figure 5 will verify and ensure the rationality of logic relationship between data in the process above.

All the data managers are managed by top data manger in the main bus described in section 4.

VI. MULTI-GRANULARITY DEMONSTRATION WITH STRONG INTELLIGENCE-AIDED DECISION SUPPORT FUNCTIONS

It's far from enough to show the properties of service planning itself. The more important thing is to show the in-depth information including the logic relationship between service planning and its related data, the occupation of all kinds of resource, matching of trains and passengers' demand, its quality and service level, etc. From the information above, it can provide powerful intelligent aided functions for manual decision. Therefore, the system should demonstrate service planning and its related data by multiple-granularity views including network, given segment, given nodes, and so on. Furthermore, all the demonstrated data should be correlated and can be extended to an integrated data demonstration platform which can show the detail of each type of key data for users to support their decision of each step in the process of optimization. The main contents in the platform are shown as Figure 6.

The demonstration can fulfill the requests from different views including network view, segments view, nodes view, etc. The suitable demonstration forms have been designed according to different views and contents. 1) The demonstration in network view will show the summary information of SP such as Figure 7(a). It shows

the services radiation from a big node, Shanghai, which indicated the farthest stations that can be reached directly

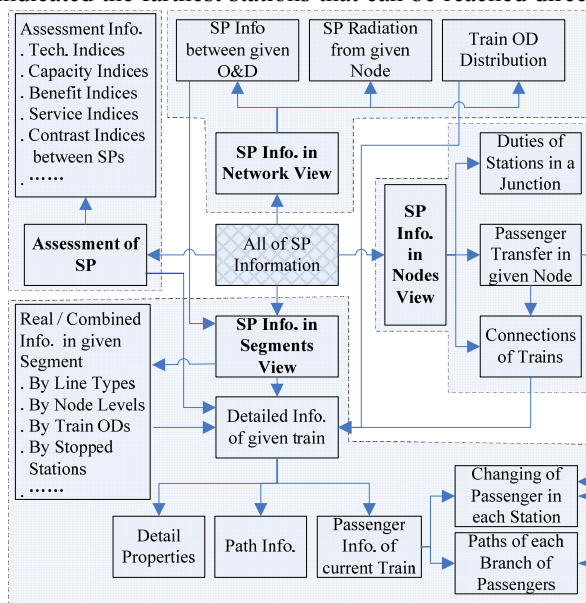

Figure 6. Demonstration of SP with multiple granularities and views

from a given node in different directions and the available train numbers. 2) In segment view, trains between given nodes will be shown by train type, node level and train OD, etc. Detailed information including detailed properties, routes, related passenger flow, etc. will be shown further. Figure 7(b-1) shows all the trains in the given segment and figure 7(b-2) shows the same service planning while the trains are combined by node levels. For example, if two trains stopped at A-B-D-E and A-C-D-E respectively and levels of node B and C were low, they would be shown as the same type of train in the

view of higher node level. So the users could watch service planning in different levels clearly. Passenger

information in the given train is also shown as Figure(c).



(a) Radiation of SP from given node

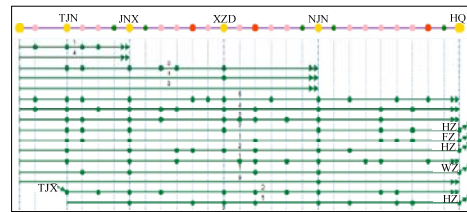

(b-1) Real Info. of SP in given segment



(b-2) Combined Info. of SP in given segment

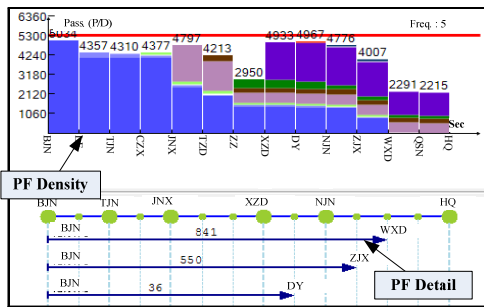

(c) Passengers assigned to the given train

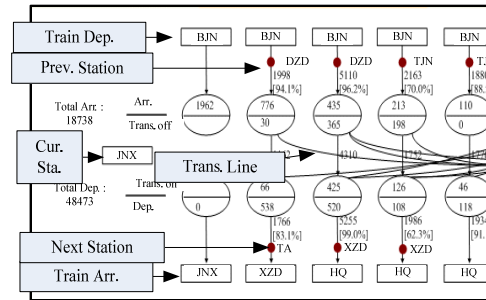

(d) Transfer info. of passengers in given node

Figure 7. Different forms of demonstration

3) In node view, the train connections and passenger transfer become the main demonstration objects. Figure 7(d) shows the passenger transfer information in a given node including the quantity of arrival, departure and transfer passengers of each train, seats occupation rate and passengers' transfer lines. 4) Different types of graphs (histogram, line graph, etc.) and tables are designed according to various assessment indices types including single value, 1 or 2 dimensions indices, etc. Furthermore, they will also be altered in real time along with the change of service planning.

Besides final service planning and its related information shown above, all kinds of basic data and medial result in optimization should be also shown in suitable forms and from different views to help the users to make their decision. For instance, when the user modified some trains, the change of passengers' choice, utilization of capacity, stopped stations and all the technical and economical indices should be updated in real time. Some data near or over the thresholds should be highlighted shown so as to help the user find the problems quickly and make some modification.

In addition to the graphs that can show the data intuitively, data tables should be also exported to give the users more detailed and precise information.

VII. REALIZATION OF THE SYSTEM

The system has been developed by C# on the basis of above. The main interface window is shown as Figure 8.

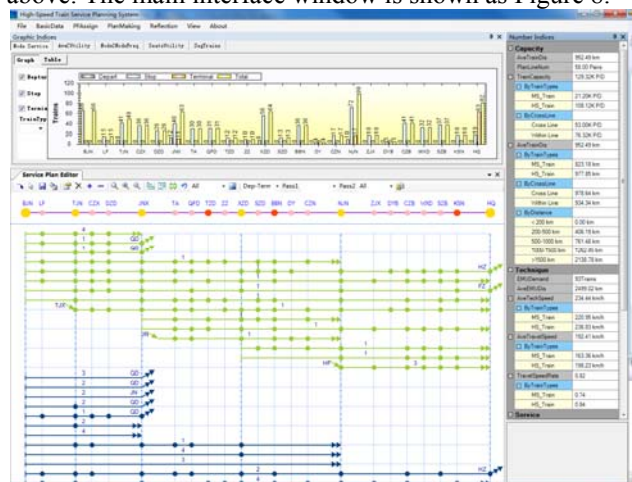

Figure 8. Main interface of the system

It had 82 DB tables to manage the basic data (Chinese railway network, passengers, resources, etc.), different service plans and their relative data, all kinds of parameters, etc. and could extract suitable data for optimization and management of service plans according to different demands.

The system combines mathematical models with user decisions closely in the process of optimization. It may

create step by step or select all or some existed data of operation mode, train OD and potential line sets and then construct a service plan by iterated optimization under the complete control of users. The changes of relative data including passengers' choice, statistics indices, detail properties, etc. will be shown as above simultaneously in the process to help users to master current service plan fully, intuitively and real-timely.

Plenty of adjustable parameters comprise by totally 4 first classes (iteration control, creation of initial service plan, stop optimization and passenger assignment) and over 100 second class items with default values had been preset into the system. In addition, abundant graphic interfaces for user decision had been set before and after each important step to adjust the parameters and results to improve the result of each step and final service plan.

We took service plan optimization for 2013 Jinghu high-speed railway operation as example. The implementation of the system is shown in Figure 9.

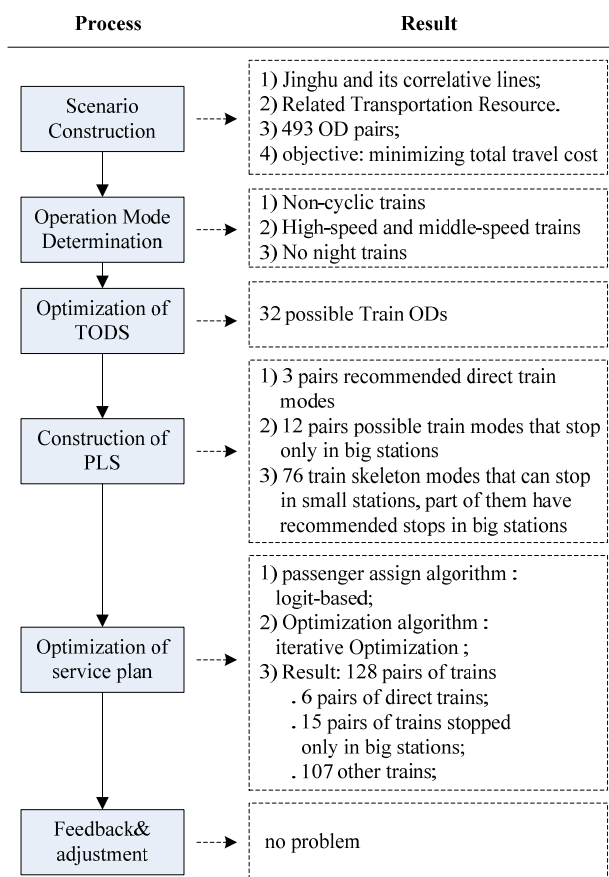

Figure 9. implementation of the system for the sample

It took about 12 minutes to get a service plan from the very beginning. In the process above, totally 4 first classes (benefit, capacity, technique and service quality) and 30 second class indices and other data described in part VI are calculated and demonstrated real-timely.

In addition to optimization, the system is also able to import all relative data (service plan, basic data, key medial data, etc.) for selected service plan at one time according to their strict logic relationship and provide the functions for users to modify service plan and its relative data manually.

VIII. CONCLUSIONS

It researched the train service planning system for high-speed railway in large scale network and proposed the basis optimization process based on the way of multi-stages and multi-levels. Several key technologies including highly configurable system control, system construction based on loosely coupled bus and hierarchical control, multi-granularity data management with strong constraints, demonstration of train service planning in multi-granularity were researched. The system has been developed by C# on the basis of above and some cases had been made. The example showed that the process and the technologies were feasible and effective.

ACKNOWLEDGEMENTS

This work was supported by the Fundamental Research Funds for the Central Universities (Beijing Jiaotong University) under Grant no. 2011JBM323. We are grateful to the referees for their valuable comments and suggestions.

REFERENCES

- [1] Claessens, M.T., van Dijk, N.M., Zwaneveld, P.J.. "Cost optimal allocation of passenger lines." in *European Journal of Operational Research*. 1998. vol. 110. pp. 474-489
- [2] Goossens, J., van Hoesel, C., Kroon, L.. "A branch-and-cut approach for solving railway line planning problems," in *Transportation Science*. 2004a. vol. 38. pp. 379-393
- [3] Bussieck, M., Linder, T., Lübbecke, M.. "A fast algorithm for near cost optimal lines plans," in *Mathematical Methods of Operations Research*. 2004. vol. 59(3). 205-220
- [4] Schöbel, A., Scholl, S.. "Line planning with minimal transfers," in *5th Workshop on Algorithmic methods and Models for Optimization of Railways*. Number 06901 in Dagstuhl Seminar Proceedings. 2006a
- [5] Scholl, S.. "Customer-oriented Line Planning [Dissertation]," University of Kaiserslautern. 2005
- [6] Goossens, J., van Hoesel, C., Kroon, L.. "On solving multi-type railway line planning problems," in *European Journal of Operational Research*. 2006. vol. 168. pp. 403-424
- [7] Sewcyk, B., Kettner, M.. "Network evaluation model NEMO," in *The World Congress on Railway Research*. Koln, Germany. 2001

- [8] Dick Middelkoop, Michiel Bouwman. "Simone: Large Scale Train Network Simulations," in *the 2001 Winter Simulation Conference*, Arlington, VA, USA, 2001
- [9] Gent, T.. "Tactical tools for integrated rail service planning," in *The World Congress on Railway Research*. Koln, Germany. 2001
- [10] SHI Feng, DENG Lianbo, LI Xinhua, FANG Qigen. "Research on Passenger Train Plans for Dedicated Passenger Traffic Lines," in *Journal of the China Railway Society*, 2004 vol 26(2). pp. 16-20
- [11] SHI Feng, ZHOU Wenliang, CHEN Yan, DENG Lianbo. "Optimization Study on Passenger Train Plans with Elastic Demands," in *Journal of the China Railway Society*, 2008 vol 30(3). pp. 1-6
- [12] FU Huiling, NIE Lei. "Research on Train Service Planning for Dedicated Passenger Traffic Lines based on Railway Junctions," in *Comprehensive Transportation*. 2008(7). pp. 52-54
- [13] FU Huiling, "Research on Theory and Methods of Line Planning for High-speed Railways [Dissertation]," Beijing Jiaotong University. 2011
- [14] FU Huiling, NIE Lei, YANG Hao, TONG Lu. "Research on the Method for Optimization of Candidate-Train-set Based Train Operation Plans for High-speed Railways," in *Journal of the China Railway Society*, 2012. vol. 32(6), pp. 1-8
- [15] DENG Lianbo, SHI Feng, ZHOU Wenliang. "Stop Schedule Plan Optimization for Passenger Train," in *Journal of the China Railway Society*. 2009. vol. 30(4). pp.
- [16] HU Hui. "The Exploitation and Research of Information System for Passenger Train Scheduling," in *Railway Transport and Economy*. 2004. vol. 26(10). pp.58-60
- [17] ZHA Weixiong, XiONG Guilin, WAN Guodong, "A Study on Passenger Train Plan Decision Support System," in *Systems Engineering*, 2004. vol. 22(6). pp. 77-82
- [18] SHI Feng, DENG Lianbo, HUO Liang. "System Design of Passenger Train Plan Optimal Reference on Passenger Special Lines," in *System Engineering*. 2006. vol. 24(11). pp. 24-30
- [19] Yang Guojun, Zheng Ying and Wang Gang. "An Application Research on the Workflow-based Large-scale Hospital Information System Integration", in *Journal of Computers*.2011. vol. 6(1)
- [20] ZHU Bin, WANG Anbao. "The Storage Technology for GIS Data Realization", in *Journal of Computers*.2011. vol. 6(10)
- [21] Lijuan Zhou, Haijun Geng, Mingsheng Xu. "An Improved Algorithm for Materialized View Selection" in *Journal of Computers*.2011. vol. 6(1)

Zhenhuan He was born in 1974. He is currently a lecturer of School of Traffic and Transportation in Beijing Jiaotong University, Beijing, China. He received the Ph. D degree in Beijing Jiaotong University in 2003. His research interests include computer application in traffic and transportation, operation of high-speed railway, design of railway passenger transportation products.

Lie Nie was born in 1970. She is currently a professor of School of Traffic and Transportation in Beijing Jiaotong University,

Beijing, China. She received the Ph. D degree in Beijing Jiaotong University in 1999. Her research interests mainly focus on operation of high-speed railway.

Huiling Fu was born in 1983. She is currently a post doctor of School of Traffic and Transportation in Beijing Jiaotong University, Beijing, China. She received the Ph. D degree in Beijing Jiaotong University in 2011. Her research interests mainly focus on service planning of high-speed railway.