

# Computer Aided Design and New Manufacturing Process of Spherical Hob

Xiaoqin Zhang<sup>1 2</sup>

1 School of Mechanical Engineering

Yan Shan University

2 Mechanical and Electrical Engineering College

Hebei Normal University of Science & Technology

Qinhuangdao China

E-mail:zxqwlc@163.com

Zhanqi Hu, Zhe Hao

School of Mechanical Engineering

Yan Shan University

Qinhuangdao China

**Abstract**—According to the working principle of spherical hob, computing formulae of normal and axial profile of the spherical hob are deduced, and calculation methods of other main parameters are introduced in the paper. Then the computer aided design and calculation of spherical hob is realized by Visual Basic programming language, which increases the calculation speed and accuracy. And the new manufacturing process of making spherical hob blade by using gear shaper cutter is put forward which can be finished on universal machine tool, so the application and popularization of spherical of hob can be promoted. At last the experiment proves that the internal gear machined by spherical hob meets the demand of precision.

**Index Terms**—spherical hob, internal gear, engagement principle, computer aided design, manufacturing process

## I. INTRODUCTION

Compare with external gearing, internal gearing not only has the characteristics of ordinary gear, but also advantages of small center distance, high contact ratio, light wear etc., which is a kind of drive with high bearing capacity, stable transmission, compact structure, high transmission efficiency and noise low. At present, the internal gearings and planetary gear reducers are widely used in hoisting, construction, metallurgical, mining and other mechanical transmissions [1].

### A. Machining of Internal Gear

At present, the common internal gear is generally machined by using gear broaching, gear shaping and gear hobbing processes.

As regards internal gear broaching, its production efficiency and machining precision is very high, but the

tool manufacture is complex, the cost of which is increased in the single small batch production. So broaching of internal gear is mainly used for small module gears of large quantities [1] [2].

Gear shaper is the most commonly used generating method, and gear shaper cutter is the most widely used after gear hob gear cutter. Because circular motion for most gear shapers is continuous, namely generating movement still exist when the gear shaper cutter retract in empty stroke, frequently, squeezing and friction take place. But this method is still used for most of the internal gear because the same gear shaper cutter can machine the gears with arbitrary tooth number and same module and pressure angle, both the standard gear and modified gear. But when gear shaping, cumulative error of tooth distance and driving chain error of machine may all be reflected to the machining gear, thereby it's not easy to work out special high precision gear by shaper cutter. As far as larger module internal gears concerned, at present, in the knowable domestic heavy machinery plant, the table diameter of the largest gear shaper is 1.5 m - 1.8 m, however the internal gear on the heavy machinery are more than this value. For example, the module of the internal gear of planetary gear reducer for cement mill of more than 2500 kW, and the maximum diameter of table of gear hobbing machine reaches to 5 m, even to 8 m. To achieve larger module internal gear, the gear shaping machine obviously can't complete, so gear hobbing may become a suitable method. By ordinary hob, the big internal gear can't be finished, thus tool problem becomes the most pressing task to solve [1] [2].

Gear hobbing is productivity high, excellent versatility, high machining accuracy, etc., which is most widely used for the machining of external gear. In June, 1949, first patents on internal gear hobbing appeared in Germany, from then on, research of internal gear hobbing technology has continued to this day. Compared to internal gear shaping technology, circular pitch accuracy

is high, and production efficiency is high because tooth surface is formed by continuous cutting. Therefore internal gear hobbing is considered to be the ideal process method instead of internal gear shaping [1].

Of course, for single internal gear processing, if the condition allows, wire - cutting can also be used. As long as the tool speed is well controlled, and the program is correct, the accuracy of internal gear machined is high, but expensive. So wire - cutting only applies to a minimal amount of small module gear, matching and repairing gear.

In order to adapt to the needs of the development of machinery industry, machining internal gear in hobbing machine by continuous process, no matter in accuracy, efficiency, cutting tool cost is ideal, and greatly improve the internal gear processing range [1].

### B. Study of Internal Gear Hob

In the science and technology developed Japan, a large amount of manpower and material resources are put into internal gear research, and good effect has also received. In 1972, UENO Taku and others demonstrated the possibility and inevitability of the internal gear hobbing in the paper "study on internal gear hob" published in proceeding for international gear device and transmission. At the end of the 70s of 20th century, on the basis of cylindrical hob, they appropriately retouched the tooth shape, making the cutter body show two parts of a curve cone and cylinder, the former is in charge of the main machining allowance, the later the final tooth shape[3].

Although this kind of hob has good cutting performance, due to different profile and complex shape of each cutter tooth, it's also very difficult to manufacture. Then AINOURA Masato professor made a further study, since 1984, successfully developed the small module spherical hob, and published five papers in succession about spherical hob design, manufacturing and hobbing process, in which machining of spherical hob and precision detecting were also talked about, perfected the spherical hob design and manufacturing theory [4][5].

After years of research, West Germany received invention patent of internal gear hob in 1979. This hob is composed of three groups of cutter teeth, the middle group of which is for rough cutting, the groups on both sides are for fine cutting. The advantages of the hob are that it can machine internal gear with different number of teeth and the same modules within a certain range. Because the position space for processing internal gear is little, and this kind of hob is wide, with the limit of tool post, it only applies to the internal gears of small or medium modules[4][5][6].

At the end of the 70s of 20th century, the former Soviet Union also got the invention patent for internal gear hob, which follows the similar principle with West Germany's, only the design of the cutter body structure and the tooth shape are different. Its cutter teeth are distributed on the same tool body, tooth profiles are formed by multiple lines. Compared to the former, this kind of cutter has smaller body, higher machining accuracy, but more difficult to manufacture [1].

In China, in 1989, Cui Yunqi Professor completed research work for spherical hob according to the generating principle in Dalian Heavy Duty Machine Tool Plant. This cutter structure is relieving, rake surface of which may be ground after blunt to keep tooth shape invariant. The machining accuracy is high, and service life is long. The main machining processes of the hob are all done in remodeled relieving lathe [1].

As stated above, spherical hob is the most ideal tool to hob internal gear. It is no widely used because of its difficult manufacturing, in which special relieving machine is generally required, causing cost extremely high. So further research of spherical hob manufacturing method in general NC machine tool, using the simplest method to hob internal gear, can greatly promote the wide use of this new technology.

In this paper, according to the working principle of spherical hob, automatic design and calculation is realized by using computer aided design, in which the calculation speed is increased and data are more accurate and reliable; In addition, a new manufacturing process realized in general machine is Put forward, which creates favorable conditions for the popularization and application of spherical hob.

## II. THE WORKING PRINCIPLE OF SPHERICAL HOB

The so-called spherical hob refers to the appearance of hob is a sphere, of which each tooth is distributed in a spherical spiral surface regularly. The Spherical hob is an effective tool in cutting internal gear, which can avoid the interference of tool with tooth profile well.

Spherical hob design is based on the principle of gear shaper cutter machining internal gear. Imagine that several semicircle gear shaper cutters (each gear shaper cutter have the same parameters) distribute homogeneously around the hob axis, of which each rake face is toward the same direction, and the teeth are arranged along the helix. This is the prototype of the spherical hob [7] [8] [9][10].

The tooth number of gear shaper cutter constituting the hob is tooth number of the hob axial section expressed by  $z_0$ , the module of gear shaper cutter is the hob axial modulus expressed by  $m_0$ , and the number of gear shaper cutter is the number of the hob chip pocket number expressed by  $z_k$ .

When the number of heads of hob is 1, the ratio of the pitch to perimeter of the reference circle of the gear shaper cutter is the tangent value of hob helical angle. Let helix angle of hob reference circle be  $\lambda$ , as shown in Fig. 1, then

$$\operatorname{tg} \lambda = \frac{\pi m_0}{\pi m_0 z_0} = \frac{1}{z_0} \quad (1)$$

While working, the hob tooth is along the tooth groove of internal gear, so hob axis must be tilted an Angle. In the section plane perpendicular to the axis of the internal gear, the tooth profile cut is the normal tooth shape of hob, so the hob normal module should be equal to the normal module of internal gear machined. So while working, the hob is equivalent to the normal tooth shape

meshing with internal gear. The normal tooth shape of hob can be regarded as a small involute gear, the tooth number of which is defined as hob imaginary number of teeth  $z_n$ , expressed as following:

$$z_n = \frac{z_0}{\cos \lambda} \quad (2)$$

To ensure the correct profile in axial and normal section, both the axial and normal section should be round, so the hob should be spherical [7] [8] [9][10].

The schematic diagram of spherical hob cutting the internal gear is illustrated in Fig. 2, in which the hob rotates on its axis  $O_m - O_m$  with angular velocity  $\omega$ , and the gear machined rotates on its axis  $O_2$  with angular velocity  $\omega_2$ . Using the face of machined gear and passed through the spherical hob center to cut the hob, the sectional shape gained is the normal section shape of hob. In the section cutter can be looked as an external gear, which is called imaginary gear of spherical hob [7].

During the process, sections of every tooth appear one by one, which is equivalent to the rotation of imaginary gear of hob on axes  $O_1$  with angular velocity  $\omega_1$ . So, in the end face of workpiece, the hobbing process can be regarded as engagement of imaginary gear with internal gear. And the tooth shape of imaginary gear is the normal tooth profile of spherical hob. If the tooth profile of internal gear is involute, the theory tooth shape of imaginary gear conjugated with it is also involute.

### III. SPHERICAL HOB DESIGN

#### A. Calculation of Spherical Hob Axial Profile

Spherical hob axial profile can be obtained through its normal tooth profile and movement relation while processed.

Coordinate systems while hob machined are illustrated in Fig. 3, in which the  $O$ - $xyz$  is a fixed coordinate system,  $O_1$ - $x_1y_1z_1$  was a dynamic coordinate system attached to the hob, and  $O_2$ - $x_2y_2z_2$  is a dynamic coordinate system attached to the cutter with which the hob is cut. When the hob rotates an angle  $\varphi_1$ , the tool correspondingly rotates an angle  $\varphi_2$ , and when the hob rotates a revolution, the machining tool correspondingly rotates a pitch of the hob axial profile [8].

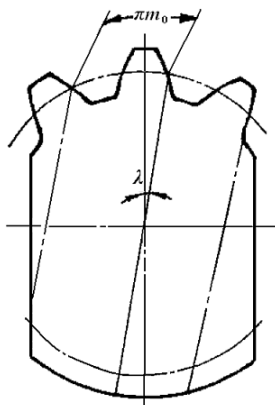

Figure 1. Helix angle of hob

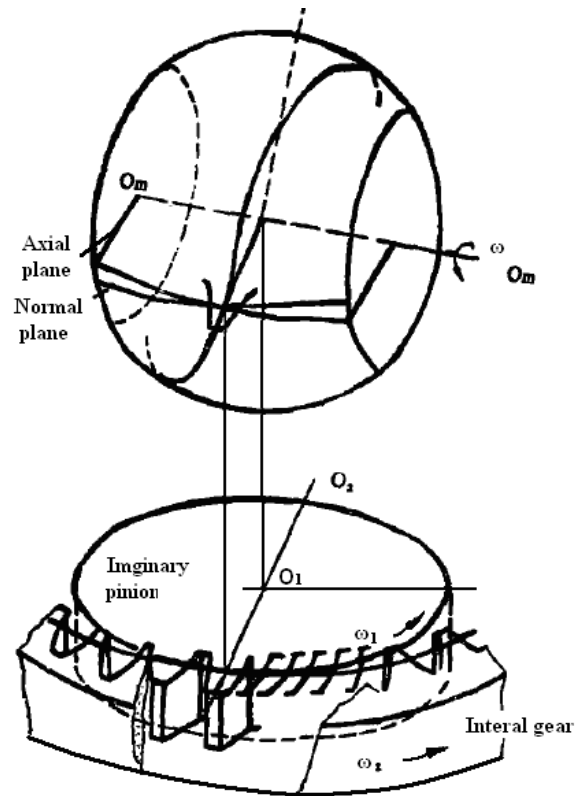

Figure 2. Principle of spherical hob

Let the tooth number of the hob in axial section plane be  $z_0$ , we have:

$$\varphi_2 = \pm \varphi_1 / z_0 \quad (3)$$

Where, "+" is for Left-hand hob, "-" right-hand hob, and

$$z_0 = z_{nt} \cos \lambda \quad (4)$$

Where,  $z_{nt}$  is the tooth number of imaginary gear.

Since the normal tooth profile of spherical hob is involute, according to the principle of which we can have:

$$\begin{aligned} x_n &= 0 \\ y_n &= r_b [\cos \Omega + (\Omega - \delta_0) \sin \Omega] \\ z_n &= r_b [\sin \Omega + (\Omega - \delta_0) \cos \Omega] \end{aligned} \quad (5)$$

Where,  $r_b$  is radius of base circle of the hob imaginary gear,  $\Omega, \delta_0$  are shown in Fig. 4.

The coordinates of normal tooth profile in  $O_2$ - $x_2y_2z_2$  are as follows:

$$\begin{aligned} x_1 &= -z_n \sin \lambda \\ y_1 &= y_n \\ z_1 &= z_n \cos \lambda \end{aligned} \quad (6)$$

From the kinematic relation of Fig. 3, we have:

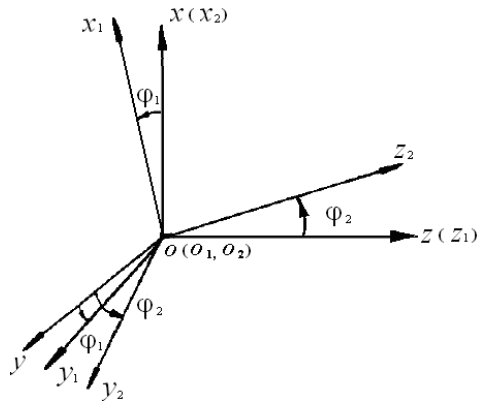

Figure 3. Coordinate systems while hob machined

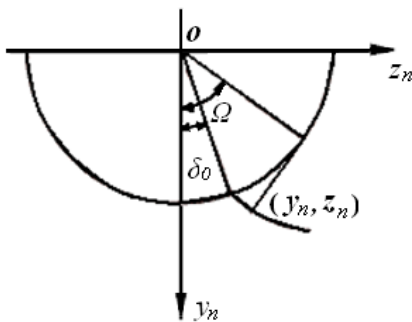

Figure 4. Normal coordinates of hob

$$\begin{aligned}
 x_2 &= x_1 \cos \varphi_1 - y_1 \sin \varphi_1 \\
 y_2 &= x_1 \sin \varphi_1 \cos \varphi_2 + y_1 \cos \varphi_1 \cos \varphi_2 + z_1 \sin \varphi_2 \\
 z_2 &= -x_1 \sin \varphi_1 \sin \varphi_2 - y_1 \cos \varphi_1 \sin \varphi_2 + z_1 \cos \varphi_2
 \end{aligned} \tag{7}$$

In axial profile of the spherical hob,  $x_2 = 0$ , so we have

$$\tan \varphi_1 = \frac{x_1}{y_1} = -\frac{z_n}{y_n} \sin \lambda \tag{8}$$

If the spherical hob designed is right hand,  $\lambda$  is substituted by  $-\lambda$  in (6), (7), (8).

**B. Parameters of Spherical Hob**

*1) The minimum length of cutting part  $L_{min}$*

As shown in Fig. 5,  $a_n$  is the normal tooth profile angle of machined gear, and  $r_2, r_a, r_f, r_j$  ( $r_j=r_2 \cos \alpha$ ) is respective radius of reference circle, addendum circle, dedendum circle and base circle.

Drawing a tangent PM on the base circle from a meshing nodes P to a point N on the addendum circle, then

$$PN = PM - MN = \sqrt{r_2^2 - r_j^2} - \sqrt{r_a^2 - r_j^2} \tag{9}$$

Set effective length of engagement is  $l'$ , then  $l' = 2PN$ ,

i.e.

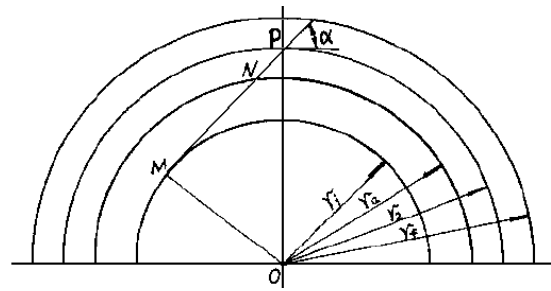

Figure 5. sketch of machined internal gear

$$L' = 2(\sqrt{r_2^2 - r_j^2} - \sqrt{r_a^2 - r_j^2}) \tag{10}$$

To ensure the gear complete profile, the minimum length of spherical hob cutting part  $L_{min}$  should meet the need of following equation:

$$L_{min} \cos \lambda = L' \cos \alpha \tag{11}$$

i.e.

$$L_{min} = \frac{2(\sqrt{r_2^2 - r_{2b}^2} - \sqrt{r_{2a}^2 - r_{2b}^2}) \cos a_{2n}}{\cos \lambda} \tag{12}$$

Where,  $a_{2n}$  is the normal tooth profile angle of machined gear;  $r_2, r_{2b}, r_{2a}$  is respective radius of reference circle, base circle and addendum circle of machined gear.

The length of hob cutting part  $L$  should satisfy  $L \geq L_{min}$ , and ensure that tooth ring is larger than two revolutions, in addition, consider the concrete structure parameters of milling head on gear hobbing machine.

*2) Axial reference pitches  $t_0$*

As shown in Fig. 6,  $\widehat{AC} = t_0$ , ( $t_0$  is axial reference pitch),  $\widehat{AB} = t_n$  ( $t_n$  is normal reference pitch, and  $t_n = \pi m_n$ ),  $R$  is reference radius ( $R = mz_n/2$ ),  $\angle BAC$  is helix angle of spherical hob ( $\angle BAC = \lambda$ ). From Fig. 6, we can derive

$$\angle AOB = \frac{t_n}{R} = \frac{\pi m_n}{\frac{1}{2} m z_n} = \frac{2\pi}{z_n} \tag{13}$$

$$\angle AOC = \frac{t_0}{R} = \frac{2t_0}{m_n z_n} \tag{14}$$

From the spherical triangle calculation formula, we have

$$tg\left(\frac{2t_0}{m_n}\right) \cdot \cos \lambda = tg\left(\frac{2\pi}{z_n}\right) \tag{15}$$

i.e.

$$t_0 = \frac{m_n z_n}{2} \arctan\left[\frac{\tan(2\pi/z_n)}{\cos \lambda}\right] \tag{16}$$

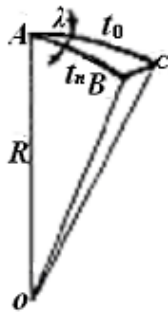

Figure 6. Axial reference pitch

3) Helix Angle of reference circle  $\lambda$  [2]

$$\tan \lambda = \frac{1}{\sqrt{z_{nt}^2 - 1}} \quad (17)$$

4) The reference diameter  $d$ :

$$d = m_n z_{nt} \quad (18)$$

Where,  $m_n$  is equal to the normal module of the machined internal gear, so  $d$  only varies with the value of  $z_{nt}$ . The number of  $z_{nt}$  should make hob cut a complete tooth depth of workpiece, and at the same time doesn't make  $d$  exceed the limits of milling cutter head structure. That is to say, both the following equations should be satisfied.

$$r_0 \leq r_i \quad (19)$$

$$d \geq 2(r_n - r_{2n} \cos \alpha + h_i) \quad (20)$$

$$\cos \alpha = \frac{\sqrt{r_{2a}^2 - (Li/2)^2}}{r_{2a}} \quad (21)$$

And  $r_a$  is the radius of hob addendum circle;  $r_i$  is the maximum allowable radius of hob,  $L_i$  is the distance between milling cutter head flange,  $h_i$  is the flange radial dimension corresponding to  $L_i$ .

Other parameters on spherical hob drawing may refer to the corresponding calculation formula of external cylindrical gear hob and gear shaper cutter.

Because of greatness of quantity and complexity of calculation, manual computation would spend a lot of time, and can't get satisfied results. In the paper, computer aided design for spherical hob is realized by using Visual Basic programming language, computation rapid, data accurate avoiding the tedious repetition work of the tool designers. It will speed up the popularization and application of the spherical hob. Software interface is shown in Fig. 7, and software design flow is shown in Fig. 8.

IV. MANUFACTURING PROCESS OF SPHERICAL HOB

A. The Structure of Spherical Hob

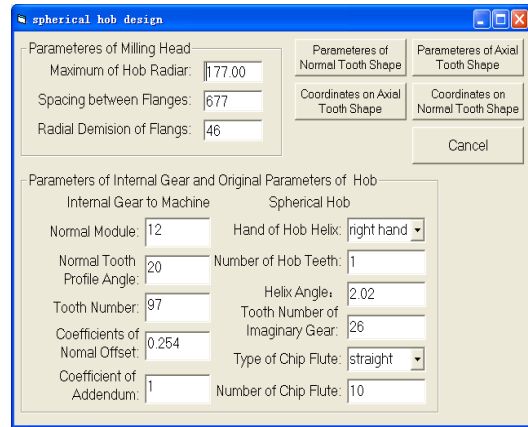

Figure 7. The interface of spherical hob CAD

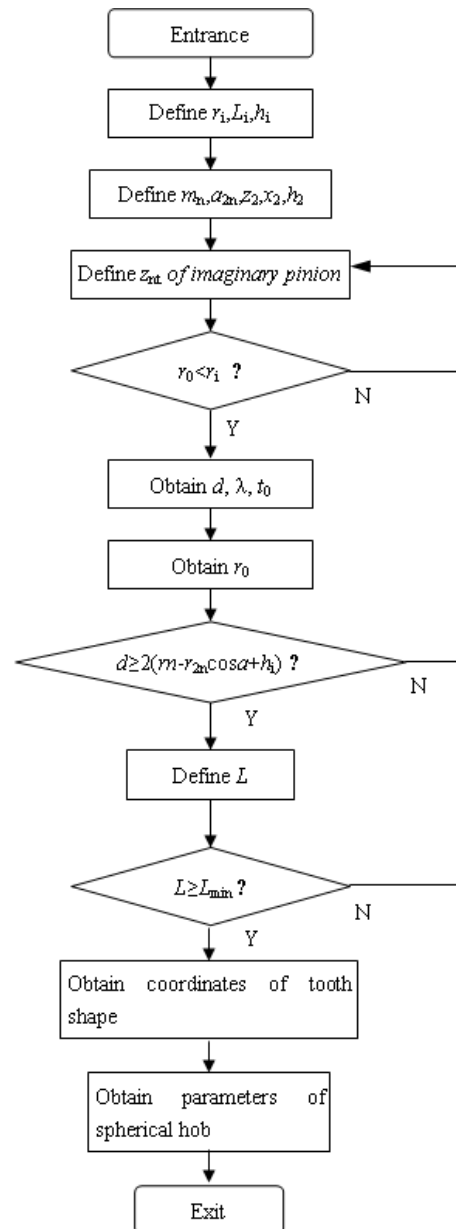

Figure 8. The flow chart of spherical hob design

Module of the spherical hob is generally big, in order to save materials, and forge blade easy, in turn, ensure the quality of heat treatment, so inserted structure is used, assembly drawing as shown in Fig. 9.

### B. Manufacturing Process Design

According to available materials, manufacturing of spherical hob has to require the special machine tool, in which the blade is first installed to the cutter body, and then the tooth profile completed in the special equipment.

The principle of Spherical hob design is based on the machining of internal gear by gear-slotting cutter. It's imagined that around the hob axis, several semicircle gear shaper cutters of which each rake face is toward the same direction are distributed homogeneously, and the teeth are arranged along the helix. From this principle, we put forward the idea that using gear shaper cutter as blade to make spherical hob in which blade is cut from the gear shaper cutter and by using wire-electrode cutting, and rake angle of blade is ground, and then is directly assembled to the cutter body. By doing so, profile processing and clearance angle grinding can be avoided, no special equipment is needed to design and manufacture, which simplify manufacturing process of spherical hob, and make the cost reduction.

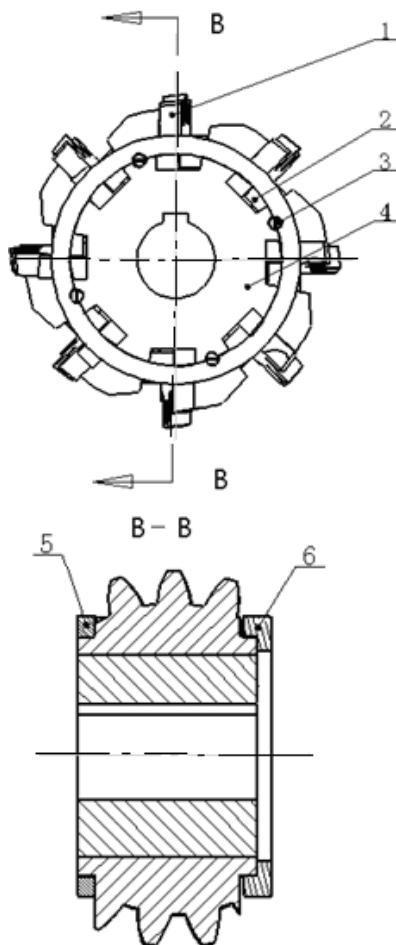

Figure 9. The structure of spherical hob

1. The blade
2. Clamping wedge
3. Screw
4. Cutter body
5. Positioning and clamping ring

### 1) The machining of cutter body

The cutter body includes inner hole, keyed ways, shaft shoulder and face. Inner hole is the installation datum fit with hob axis to transfer torque with keyway, of which diameter should be big enough to ensure the rigidity. Cutter body structure design of Spherical hob is shown in Fig.10. Out circle, shoulder, face, rough machining and semi-finishing of inner hole are finished in ordinary lathe.

The machining of hob chip pocket: machined on the milling machine with the hole as positioning reference, ensuring the angle between hob chip pocket and the axis of cutter body equal the hob helix angle, dividing evenly. The machining of spherical spiral support plate: finished on the 3-axis NC milling machine.

### 2) The machining of hob blade

The structure of blade is shown in Fig. 11.

#### a) The choice of gear shaper cutter

According to the module and diameter of spherical hob, determine the size of the gear shaper cutter. And according to the blade number of hob and the tooth number of the gear shaper cutter used, determine the amount of gear shaper cutter required to make maximum use of the gear shaper cutter.

#### b) The coarse grinding

On surface grinding machine, using the small end face as positioning datum, the big end face is coarse ground until the rake angle is zero. Then using the big end face as datum, the small end face is coarse ground. At last, the width of the gear shaper cutter is cut to the right size.

#### c) Wire-electrode cutting

The blade is wire-electrode by using cut small end face 1 and excircle 2 as positioning datum. First, the gear shaper cutter ground is installed on the slow-feeding NC wire-cut machine. While cutting, the wire inclines an angle equal to spherical hob helix angle, the gear shaper cutter is cut into certain number of blades through the relative movement between the wire and the work. After each blade is cut, the gear shaper cutter is needed to rotate an angle (equal to  $30 + \theta/n$ , in which  $\theta$  is the angle between two arbitrary adjacent blades,  $n$  is the blade number of hob.) on own axis.

#### d) Heat treatment

The blades cut is hardened, and tempered to improve the mechanical properties.

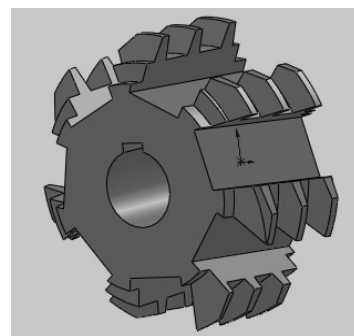

Figure 10. The structure of hob body

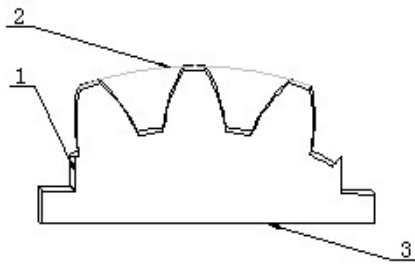

Figure 11. Blade structure of hob

1. Positioning surface 2. Excircle of tooth 3. Underside

e) *Grinding*

With big end face as the datum, the small end face is ground, and with small end face as the datum, the big end face is ground. The base surface 3 is ground with cylindrical 2 for reference. And the left locating surface 1 is ground with cylindrical 2 and small end face as datum.

3) *Spherical hob assembly:*

The spherical hob assembly is shown as Fig. 9.

a) Put the blade 1 on the blade groove, then the clamping wedge block 2, but not wedged tight.

b) The grinding of side surface of blade left shoulder and cylindrical of cutter body left shoulder are finished on the grinding machine simultaneously, and the right sides of those together, and right side of blade and cutter body axial clamping surface synchronously, to prepare the hot mounting of positioning ring 5 and clamping ring 6.

c) The locating ring is hot mounted on a side of the cutter body 4, then knock on the other side of the blade 1 and cutter body 4 to make positioning ring 5 closely fit with axial positioning surface of blade 1, realizing axial positioning and radial clamping.

d) The clamping ring is set on right side of cutter body 4 with shrinkage fit, realizing radial and axial clamping. Then wedge-caulking the clamping wedge block 2 to realize tangential clamping.

e) Tap respectively the screw holes on the positioning ring 5, clamping ring 6 and wedge block 2, and tight the screws.

f) *Lapping inner hole.*

The assembly clamping force may make the hole deform slightly, so the inner hole must be lapped.

The spherical hob sample finished is shown in Fig. 12.

V. ERROR ANALYSIS OF SPHERICAL HOB

A. *Experiment of Spherical Hob Processing Internal Gear*

The structure parameters of spherical hob are as follows: normal module  $m_n = 12$ , normal pressure angle  $a_n = 20^\circ$ , teeth number of imaginary gear  $Z_n = 26$ ; number  $Z_k = 10$ , hob chip pocket helix direction: straight flute, number of heads of hob  $N = 1$ , the sense of screw: left-hand, helix Angle  $\lambda$ ,  $2.02^\circ$ , modification coefficient

$x_0: 0.1$ , addendum coefficient  $h = 1.3$ , reference diameter  $D = 312$ , addendum circle diameter  $D_0 = 345.6$ .

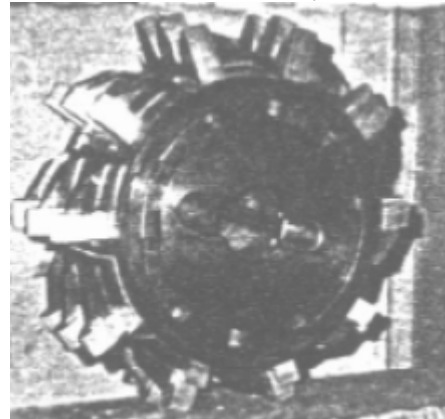

Figure 12. Spherical hob sample

Basic parameters of machined internal gear are as follows: normal module  $m_n = 12$ , normal profile angle  $a_n = 20^\circ$ , addendum coefficient  $h' = 1$ , number of teeth  $Z = 97$ , normal modification coefficient  $x_n = 0.254$ , precision grade: 877HL JB179-83, material: 42CrMo HB262-302.

Cutting characteristics: speed of spherical hob  $n_0 = 35$  r/min ( $V = 34.3$  m/min), axial feed  $s_0 = 1.2$  mm/r.

The experimental results: surface roughness  $R_a$  reached 1.6; The profile error of workpiece: left tooth surface  $\Delta ff = 0.021$  mm; Right tooth surface  $\Delta ff = 0.025$  mm; Tooth error  $\Delta ff = 0.02$  mm.

B. *Error Analysis*[6]

Accuracy grade and surface roughness of machined gear is ensured by the machine-tool-workpiece system and such factors as adjusting operations. Because of these aspects are inevitably exist error, inevitable in enhancing the machining accuracy of the gear.

1) *The accuracy of gear blank itself*

The accuracy of the gear blank itself is one of the important factors influencing radial run-out and tooth error of gear ring. While mounting gear blank, use gear ring as reference for center adjusting, and end face for positioning. The hole diameter tolerance and face run-out of processed internal gear ring may cause geometric eccentric of gear blank, therefore, while cutting, the distance between cutter and geometric center of the gear blank would change periodically, so the gear teeth cut out is also various.

2) *Installation error of the workpiece*

Even though the gear blank itself is machined accurately enough to have no geometric eccentric, if not installed correctly, still make eccentric and tilt of the work, in turn, produce radial run-out and tooth error.

3) *Influence of machine tool*

Since gear hobbing is based on generating principle, the transmission chain from tool to gear blank must be kept the movement accuracy according to a certain ratio. The manufacturing and assembly error of transmission key will concentrated reflect on the two ends of the chain, which would produce non homogeneity of relative motion between spherical hob and the internal ring of



machining gear, causing motion eccentric, influencing the accuracy of the gear.

4) Influence of hobbing process

Tooth shape of machined internal gear is enveloping formed by a certain amount of continuous positions of tooth participated in cutting of spherical hob. During the forming of a tooth groove, the number of machining cutter teeth is limited, and therefore the involute profile constituted is not a smooth curve, leaving a convex edge between two enveloping line on the tooth surfaces, its height  $\Delta$  as shown in Fig. 13, which can be expressed as

$$\Delta = \pi m_n^2 z_0^2 \sin \alpha / (4 z_2 z_k)^2 \quad (22)$$

Where  $z_0$  is the number of heads of hob ( $z_0 = 1$ ),  $a$  is indexing circle pressure angle ( $a = 20^\circ$ ),  $z_2$  is tooth number of gear ( $z_2=97$ ),  $m_n$  is normal module of gear ( $m_n = 12$ ),  $z_k$  is circular tooth number of hob, i.e., number of chip pockets, ( $z_k=10$ ). From (14), we have  $\Delta = 0.007$  mm.

In the gear hobbing process, besides the rotation of spherical hob  $n_c$  and gear blank  $n_w$ , the feeding movement of hob along the axial  $s_0$  is included. The trace formed by axial feed may be translated into tooth profile error in a certain extent, i.e., surface waviness  $\Delta f$ , which can be expressed as

$$\Delta f = \sin a_{0n} s_0^2 / (4 D_1 \cos^2 \beta) \quad (23)$$

Where  $a_{0n}$  is normal pressure angle of tooth shape of spherical hob ( $a_{0n} = 20^\circ$ ),  $s_0$  is axial feeding ( $s_0 = 1.2$  mm/r),  $D_1$  is addendum circle diameter of spherical hob ( $D_1 = 345.6$ ) and  $\beta$  is the spiral angle of indexing circle of internal gear processed ( $\beta = 0^\circ$ ).

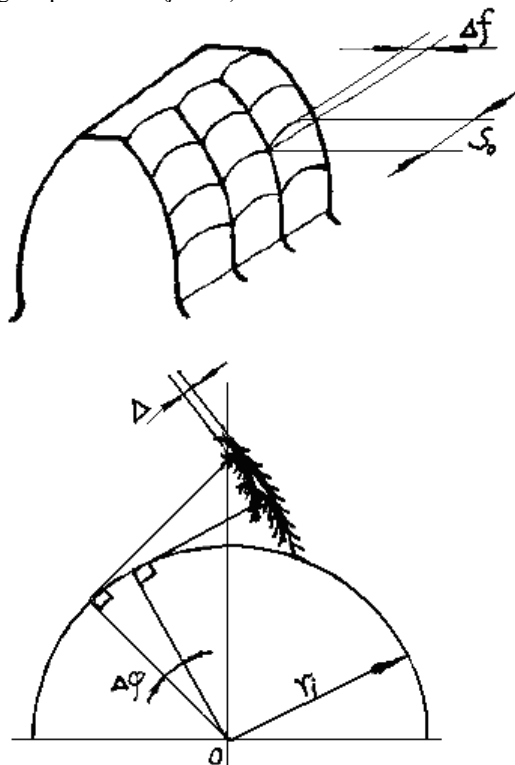

Figure 13. The influence of hobbing process

From (23), we have  $\Delta f = 0.0004$  mm.

Therefore, the envelope and axial feed may all bring profile error and influence the surface roughness of gear face.

VI. CONCLUSION

Based on the principle of spherical hob machining internal gear, as well as the analysis of the gear tooth shape theory and the design of auxiliary equipment, and test validation, draw the following conclusions:

1. Based on the principle of gear shaper cutter machining internal gear, imagine that several semicircle gear shaper cutters distribute homogeneously around the hob axis, and the teeth of which are arranged along the helix. The starting point of this design is correct.
2. Axial profile of the spherical hob take the form of involute curve, compared with the existing other kinds of internal gear hobs, which is simple, good approximation and easy to manufacture.
3. The precision and productivity of spherical hob processing inner gear are both higher than the existing other processing method.
4. The design and manufacture of spherical hob aims at solving the critical problems of machining inner gear at present, which can resolve the limitations of current internal gear processing equipment and expand processing range of the gear hobbing machine.

The design of the spherical hob in the paper put forward a new theory basis for the design and machining of internal gear hob, but due to the limitation of conditions, there are still many problems to be further studied:

1. Further optimization of tooth axial shape of spherical hob, searching for more ideal tooth edge curve to apply higher accuracy internal gear.
2. Improving the material of cutting tool to increase the tool's durability, applying finish of medium hard tooth surface and hard tooth surface.
3. Doing more cutting test, on the base of obtaining a large number of data, selecting the best cutting parameters.

VII. REFERENCES

- [1] Zhanqi Hu, Yunqi Cun, "Present situation and the increasing tendency of large internal gear processing technology", Tool Technology, vol. 43, no. 6, pp.17-21, 2009.
- [2] Zhejun Yuan, Huaming Liu, Gear Tool Design, New Age Press, China,1983
- [3] Ueno Taku, TERASHIMA Kenichi, SAKAMOTO Masafumi, "Studies on the Internal Gear Hobs : Hobs working like the broach and their cutting test", Bulletin of JSME, vol. 115, no. 18, pp.73-80, 1975
- [4] AINOURA Masato, HIROO Yasuaki, YONEKURA Masataka, "A Research on Generating Hobbing of Internal Gears : 1st Report, On the Shape of Spherical Hob Holding a Set Angle of 0 Degree", Transactions of the Japan Society of Mechanical Engineer, Part C, vol.432, no.48, pp.1227-1234, 1982
- [5] AINOURA Masato, HIROO Yasuaki, YONEKURA Masataka, "A Research on Generating Hobbing of Internal Gears : 2nd Report, On the Design of Spherical Hob",



Transactions of the Japan Society of Mechanical Engineer, Part C, vol.439,no.49, pp. 457-464,1983

- [6] AINOURA Masato, HIROO Yasuaki, YONEKURA Masataka, "A Research on Generating Hobbing of Internal Gears: 3rd Report, On Device for Spherical Hob Manufacturing" Transactions of the Japan Society of Mechanical Engineer, Part C, vol.453, no.50, pp. 867-874,1984
- [7] Yunqi Cun, "Spherical hob theory study", Tool Technology, vol.132, no. 2, pp.54-61, 1996.
- [8] Yuejin Wang, "Study on helical surface of spherical hob", Tool Technology, no.01, pp.20-26, 1990
- [9] Jing Zhang, Feng Wei, Mingxi Zhang, "The Research on the Application to Digital Image Technology in Hypoid Gear Contact Zone Detection", Journal of Computers, Vol. 6, no.7, 1519-1526,2011
- [10] Huimin Dong, Zhengdu Zhu, Weidong Zhou, "Dynamic Simulation of Harmonic Gear Drives Considering Tooth Profiles Parameters Optimization", Journal of Computers Vol. 7, no.6, 1429-1436,2012



**ZHANG Xiaoqin**, Female, (1971-), born in Tangshan city, Hebei Province, China, A PHD Candidate, School of Mechanical Engineering, Yanshan University, Qinhuangdao, China, major in Mechanical Manufacture and it's Automation. She is currently a lecturer of College of Mechanical and Electronic Engineering, Hebei Normal University of

Science and Technology, Qinhuangdao, China. Her research activity mainly focuses on Mechanical CAD/CAM.

**HU Zhanqi**, Male, (1956-), a professor, supervisor of PHD candidate of School of Mechanical Engineering, Yanshan University, Qinhuangdao, China. His research activity mainly focuses on numerical control technology and intelligent manufacturing.

**HAO Zhe**, female, (1987-), a master degree candidate of School of Mechanical Engineering, Yanshan University, Qinhuangdao, China, major in Mechanical Manufacture and it's Automation.